

Custom manufacturing

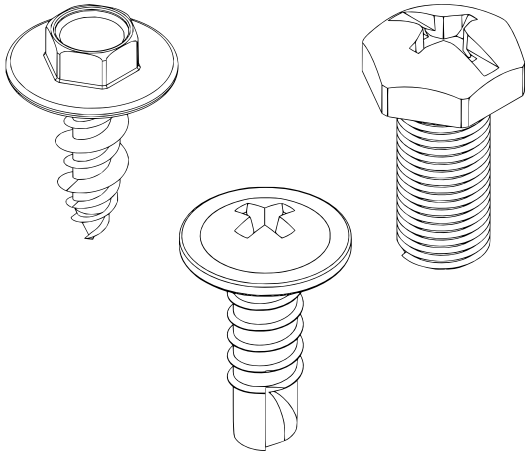

Special processes

Our expertise, engineering team, and tool manufacturing workshop give us the ability to produce non-standard parts. We carefully review your requirements and manufacture the right tool for you product.

We also have a trimming and deburring machine that manufactures parts with complex geometries that are difficult to achieve through cold forming.

Available materials*

Low-carbon steel	1018-1022, 10B22
Stainless Steel	300 & 400 series
Aluminium Alloy	5052
Brass	CDA260
Copper	CDA102

*We can review other materials upon request.

Over 50 years in the fastener manufacturing market have endowed us with significant expertise in the field of fastenings, allowing us not only to meet our customers' requirements but also to help them **reduce** the fastening **TOTAL COST**. We make our entire know-how and expertise available to provide specialized technical consultancy and bring your special manufacturing requirements to life.

Proudly, we can say that our strength lies in special manufacturing!

Production Capacity

We have the capacity to produce up to 70 million units per month, using a variety of materials, with diameters of up to **3/8"** (10 mm) and lengths of up to **4"** (100 mm).

We offer a variety of finishes which can accommodate to your specific corrosion-resistance needs, with finishes of up to 500 hours in the Salt Spray Test as per ASTM B117.

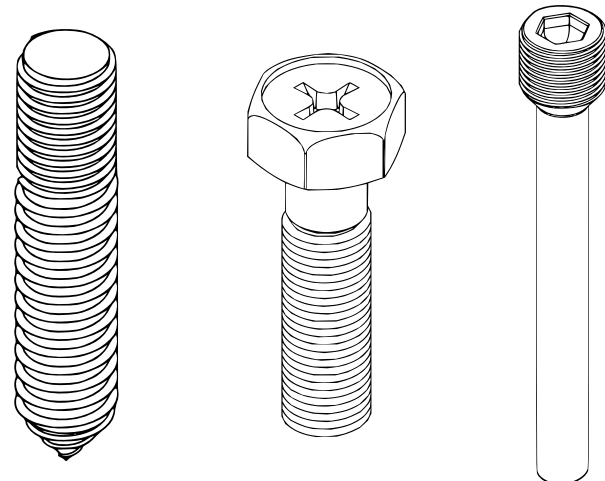

For additional information just scan the QR code and contact us!

